

AIR COOLED CONDENSER

550 RPM / FLYING BIRD 2

Catalog 630

April 2004



Description:

Witt's Remote Air Cooled Condensers are designed to provide the optimum in heat transfer efficiency and are constructed for years of reliable performance. The large air cooled condenser, now the accepted standard, is more than an assemblage of fans and coil. It is a highly engineered element of the refrigeration system. The reliability of the system depends as much on the performance of the condenser as on the performance of the compressor. Only the highest grades of commercially available Aluminum, Copper and galvanized steel go into the manufacture of each air cooled condenser. To ensure trouble free installation and operation, every unit must pass the high standards of our Quality Control Program at each stage of production.

Features:

- Direct drive arrangement
- Vertical air flow
- WCE series uses 550 RPM motors, for high performance
- WCE series available with either the patented Flying Bird 2 assembly or standard metal fan blades
- Reduced decibel ratings from 1140 RPM motors
- Motors have inherent thermal overload protection
- Copper tube, Aluminum finned coils
- Leak tested at 450 PSIG
- Vinyl coated heavy gauge steel fan guards for safety and long life
- Heavy gauge galvanized steel construction for superior corrosion resistance
- Custom circuited coils for optimum performance based on actual application requirements
- UL and cUL Listed

Options:

- Fan cycling head pressure control
- Flooded head pressure control
- Sub-cooling circuit
- Multi-circuiting
- Copper fins
- Wide selection of coated coils for corrosion protection
- Through-the-door disconnect switch
- Individual motor fusing
- Individual motor contactors
- Splitting relay
- Control board with transformer



Nomenclature

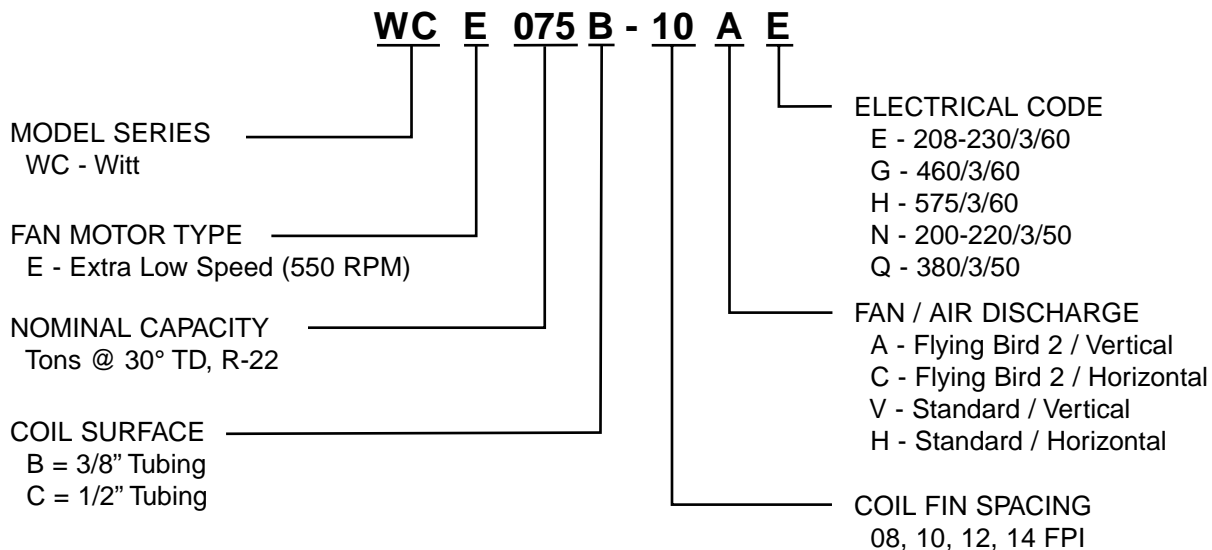

Witt's New **FOURTEEN FAN** air cooled condenser on shipping skid.

Example of the *Flying Bird 2* impeller.



The *Flying Bird 2* units incorporates many key features:

- Reduces db levels
- Improved performance
- Configuration up to 14 fans
- Capacity up to 152 tons at 30°TD
- Non-corrosive durable injected composite plastic blades
- Ideal for coastal applications

NOTE: Shown with optional Copper Fin Coil

Selections

For the proper selection of an air cooled condenser it is necessary to know the total heat rejection of the condenser. The Total Heat of Rejection (THR) is equivalent to the sum of the Net Refrigerating Effect (NRE) plus the heat of compression added by the compressor. The amount of heat added to the refrigerant will depend on the style of compressor, open or suction cooled, and the operating conditions of the system.

Whenever the THR values are available from the compressor manufacturer they should be used in selecting a condenser.

For those cases in which the THR data is unavailable it can be quickly estimated using the following equation and the appropriate factor from Tables 1 or 2.

Eq. (1) THR = Compressor Capacity x Heat Rejection Factor

In those cases where the refrigeration system is of a multiple or cascade style, the following equations should be used to estimate the total heat of rejection.

Open Compressor

Eq. (2) THR = Compressor Capacity + (2545 x BHP)

Suction Cooled Compressor

Eq. (3) THR = Compressor Capacity + (3413 x KW)

Altitude at which a condenser is to operate will also affect its capacity. In order to correctly select a condenser at a specific altitude, use the following equation and the appropriate correction factor from Table 3.

Eq. (4) THR Corrected = THR Design x Altitude Correction Factor

Selection Example

Given:

Altitude 5000 ft.
 Ambient Temperature 100°F
 Evaporator Temperature 20°F
 Maximum Condensing Temperature 110°F
 Refrigerant R-22
 Compressor Capacity (NRE) 225,000 BTUH
 Compressor Type Suction Cooled

Assume compressor THR is not available

Calculate:

1. Total Heat Rejection
2. Design temperature difference
3. Witt condenser size
4. Actual system TD
5. Actual condensing temperature

Solution:

1. Calculate the system THR from Table 2, a suction cooled compressor, at 110°F condensing temperature and 20°F evaporator temperature, will have a heat rejection factor of 1.33.

THR = Compressor Capacity x Heat Rejection Factor

THR = 299,250 BTUH

THR Corrected "Altitude" = THR x Altitude Corr. Factor

THR Corrected "Altitude" = 336,656 BTUH

2. Design TD = Condensing Temp. - Ambient Temp.

Design TD = 10°F

3. Select condenser size:

From page 5 locate double width WCE section of the page.

Then using the TD of 10°F calculated in Step 2, go to the appropriate column and select a condenser whose THR equals or exceeds that of which we calculated in Step 1; 336,656 BTUH.

A model WCE075B-08A with a THR of 352,000 BTUH will meet the required conditions.

4. Eq.(5) Actual TD = $\frac{\text{Design TD} \times \text{Design THR}}{\text{Actual Condenser Capacity at Design TD}}$

Actual TD = 9.6°F

5. Eq.(6) Actual Condensing Temp. = Actual TD + Ambient Temp.

Actual Condensing Temp. = 109.6°F

HEAT REJECTION FACTORS

TABLE 1 - OPEN COMPRESSOR

EVAP. TEMP.	CONDENSING TEMPERATURE							
	90°	100°	105°	110°	115°	120°	125°	130°
-40°	1.45	1.48	1.52	1.56	1.58	1.61		
-35°	1.42	1.45	1.47	1.51	1.54	1.57		
-30°	1.39	1.41	1.44	1.47	1.50	1.53		
-25°	1.37	1.39	1.41	1.44	1.46	1.49	1.52	
-20°	1.34	1.37	1.39	1.41	1.43	1.45	1.48	1.51
-15°	1.31	1.34	1.37	1.38	1.40	1.42	1.45	1.47
-10°	1.28	1.31	1.33	1.37	1.38	1.40	1.42	1.45
0°	1.24	1.28	1.29	1.32	1.33	1.35	1.38	1.41
10°	1.21	1.24	1.26	1.28	1.30	1.31	1.34	1.36
20°	1.18	1.21	1.23	1.24	1.26	1.28	1.30	1.32
30°	1.15	1.18	1.20	1.21	1.23	1.24	1.26	1.28
40°	1.13	1.15	1.17	1.18	1.19	1.20	1.22	1.24
50°	1.11	1.13	1.14	1.15	1.16	1.17	1.18	1.20

TABLE 2 - SUCTION COOLED COMPRESSOR

EVAP. TEMP.	CONDENSING TEMPERATURE							
	90°	100°	105°	110°	115°	120°	125°	130°
-40°	1.67	1.71	1.75	1.79	1.84	1.90		
-35°	1.63	1.67	1.70	1.73	1.78	1.83		
-30°	1.58	1.62	1.65	1.68	1.72	1.77		
-25°	1.54	1.58	1.60	1.64	1.67	1.71	1.76	
-20°	1.49	1.53	1.56	1.58	1.63	1.66	1.70	1.75
-15°	1.46	1.50	1.52	1.54	1.58	1.62	1.65	1.69
-10°	1.42	1.46	1.48	1.50	1.53	1.57	1.62	1.64
0°	1.36	1.40	1.42	1.44	1.47	1.50	1.54	1.56
10°	1.31	1.34	1.36	1.38	1.40	1.43	1.47	1.49
20°	1.26	1.29	1.31	1.33	1.35	1.37	1.40	1.43
30°	1.22	1.25	1.26	1.28	1.30	1.32	1.35	1.37
40°	1.18	1.21	1.22	1.24	1.25	1.27	1.30	1.32
50°	1.14	1.17	1.18	1.20	1.21	1.23	1.25	1.27

TABLE 3 - Altitude Correction Factor (ft.)

Altitude	Sea Level	1000	2000	3000	4000	5000	6000	7000	8000	9000	10000
Factor	1.0	1.029	1.052	1.076	1.101	1.125	1.151	1.177	1.204	1.231	1.260



Performance Data - Single Fan Width Models†

WCE Model	Fan Conf.	STANDARD METAL BLADE, R-22†					FLYING BIRD 2 BLADE, R-22†				
		Total Heat of Rejection, MBH					Total Heat of Rejection, MBH				
		1°TD	10°TD	15°TD	20°TD	30°TD	1°TD	10°TD	15°TD	20°TD	30°TD
017B-08	1 x 2	6.6	66	99	132	198	6.8	68	102	136	204
017B-10	1 x 2	7.4	74	112	149	223	7.7	77	115	153	230
017B-12	1 x 2	8.1	81	121	161	242	8.3	83	125	166	249
017B-14	1 x 2	8.6	86	129	171	257	8.8	88	132	176	265
019B-08	1 x 2	8.6	86	129	172	258	8.9	89	133	177	266
019B-10	1 x 2	9.5	95	143	190	286	9.8	98	147	196	294
020B-12	1 x 2	10.0	100	150	200	300	10.3	103	154	206	309
020B-14	1 x 2	10.2	102	154	205	307	10.5	105	158	211	316
021B-08	1 x 2	9.9	99	148	198	297	10.2	102	153	204	306
021B-10	1 x 2	10.5	105	158	210	315	10.8	108	162	216	325
021B-12	1 x 2	10.8	108	162	216	324	11.1	111	167	223	334
022B-14	1 x 2	11.3	113	169	226	339	11.6	116	174	232	349
028B-08	1 x 3	13.3	133	199	265	398	13.7	137	205	273	410
028B-10	1 x 3	14.3	143	215	287	430	14.8	148	222	295	443
030B-12	1 x 3	15.1	151	226	302	453	15.5	155	233	311	466
030B-14	1 x 3	15.5	155	233	310	465	16.0	160	239	319	479
032B-08	1 x 3	15.0	150	224	299	449	15.4	154	231	308	462
032B-10	1 x 3	15.7	157	236	314	471	16.2	162	243	323	485
032B-12	1 x 3	16.4	164	246	328	492	16.9	169	253	338	506
032B-14	1 x 3	16.5	165	248	330	496	17.0	170	255	340	510
037B-08	1 x 4	17.6	176	264	352	528	18.1	181	272	363	544
037B-10	1 x 4	19.0	190	285	380	570	19.6	196	294	391	587
040B-12	1 x 4	20.0	200	300	400	600	20.6	206	309	412	617
040B-14	1 x 4	20.5	205	307	409	614	21.1	211	316	421	632
043B-08	1 x 4	19.8	198	297	396	595	20.4	204	306	408	612
043B-10	1 x 4	21.1	211	317	423	634	21.8	218	326	435	653
043B-12	1 x 4	21.4	214	321	428	643	22.1	221	331	441	662
045B-14	1 x 4	22.5	225	338	451	676	23.2	232	348	464	696
050*-08	1 x 5	22.3	223	335	446	669	23.0	230	344	459	689
050*-10	1 x 5	24.3	243	365	487	730	25.1	251	376	501	752
050*-12	1 x 5	25.3	253	379	506	759	26.0	260	391	521	781
050*-14	1 x 5	26.0	260	390	520	780	26.8	268	402	536	803
052*-08	1 x 5	25.4	254	380	507	761	26.1	261	392	522	783
052*-10	1 x 5	26.7	267	401	534	802	27.5	275	413	550	825
055*-12	1 x 5	27.7	277	415	554	830	28.5	285	427	570	855
055*-14	1 x 5	28.1	281	422	562	844	28.9	289	434	579	868
062*-08	1 x 6	31.5	315	473	630	945	32.4	324	487	649	973
062*-10	1 x 6	33.7	337	505	674	1011	34.7	347	520	694	1040
064C-12	1 x 6	34.0	340	510	680	1020	35.0	350	525	700	1050
066C-14	1 x 6	34.4	344	516	688	1032	35.4	354	531	708	1062
071*-08	1 x 7	36.7	367	551	735	1102	37.8	378	567	756	1134
074*-10	1 x 7	39.2	392	587	783	1175	40.3	403	605	806	1209
076C-12	1 x 7	39.6	396	595	793	1189	40.8	408	612	816	1224

† - For R-404A applications multiply required capacity ratings by 0.98 and for R-134a selections multiply required capacity by 1.05 then make selection from R-22 table using corrected capacity.

Shaded areas indicate that specific models will require 1/2" diameter tubing over the standard 3/8" diameter tubing at certain operating TD's. At TD's not listed in the performance tables, conversion to 1/2" tube diameter tubing may be required for optimal performance. Contact factory for non-standard conditions.

* - Change asterisk in model number to a "B" for 3/8" tubes or a "C" for 1/2" tubes when specifying model number.

Performance Data - Double Fan Width Models†

WCE Model	Fan Conf.	STANDARD METAL FANS, R-22†					FLYING BIRD 2 BLADE, R-22†				
		Total Heat of Rejection, MBH					Total Heat of Rejection, MBH				
		1°TD	10°TD	15°TD	20°TD	30°TD	1°TD	10°TD	15°TD	20°TD	30°TD
034B-08	2 x 2	13.2	132	198	264	396	13.6	136	204	272	408
034B-10	2 x 2	14.9	149	223	297	446	15.3	153	230	306	459
034B-12	2 x 2	16.1	161	242	323	484	16.6	166	249	332	498
034B-14	2 x 2	17.1	171	257	343	514	17.6	176	265	353	529
038B-08	2 x 2	17.2	172	258	344	516	17.7	177	266	354	531
038B-10	2 x 2	19.0	190	286	381	571	19.6	196	294	392	588
041B-12	2 x 2	20.0	200	300	400	600	20.6	206	309	412	617
041B-14	2 x 2	20.5	205	307	409	614	21.1	211	316	421	632
044B-08	2 x 2	19.8	198	297	396	594	20.4	204	306	407	611
044B-10	2 x 2	21.0	210	315	421	631	21.6	216	325	433	649
044B-12	2 x 2	21.6	216	324	432	649	22.3	223	334	445	668
046B-14	2 x 2	22.6	226	339	451	677	23.2	232	349	465	697
051B-08	2 x 3	20.9	209	313	418	626	21.5	215	322	430	645
051B-10	2 x 3	23.4	234	350	467	701	24.0	240	361	481	721
051B-12	2 x 3	24.6	246	369	492	737	25.3	253	380	506	759
051B-14	2 x 3	25.8	258	387	515	773	26.5	265	398	531	796
056B-08	2 x 3	26.5	265	398	530	796	27.3	273	410	546	819
056B-10	2 x 3	28.7	287	430	574	861	29.5	295	443	591	886
060B-12	2 x 3	30.2	302	453	604	906	31.1	311	466	622	932
060B-14	2 x 3	31.0	310	465	620	930	31.9	319	479	638	958
065B-08	2 x 3	29.9	299	449	598	898	30.8	308	462	616	924
065B-10	2 x 3	31.4	314	471	628	942	32.3	323	485	647	970
065B-12	2 x 3	32.8	328	492	656	984	33.8	338	506	675	1013
065B-14	2 x 3	33.0	330	496	661	991	34.0	340	510	680	1021
075B-08	2 x 4	35.2	352	528	704	1057	36.3	363	544	725	1088
075B-10	2 x 4	38.0	380	570	760	1140	39.1	391	587	783	1174
080B-12	2 x 4	40.0	400	600	800	1200	41.2	412	617	823	1235
080B-14	2 x 4	40.9	409	614	819	1228	42.1	421	632	843	1264
086B-08	2 x 4	39.6	396	595	793	1189	40.8	408	612	816	1224
086B-10	2 x 4	42.3	423	634	846	1269	43.5	435	653	871	1306
086B-12	2 x 4	42.8	428	643	857	1285	44.1	441	662	882	1323
088B-14	2 x 4	45.1	451	676	902	1353	46.4	464	696	928	1393
100*-08	2 x 5	44.6	446	669	892	1338	45.9	459	689	918	1378
100*-10	2 x 5	48.7	487	730	974	1461	50.1	501	752	1002	1504
100*-12	2 x 5	50.6	506	759	1012	1518	52.1	521	781	1042	1563
100*-14	2 x 5	52.0	520	780	1040	1561	53.6	536	803	1071	1607
105*-08	2 x 5	50.7	507	761	1015	1522	52.2	522	783	1044	1567
105*-10	2 x 5	53.4	534	802	1069	1603	55.0	550	825	1100	1651
110*-12	2 x 5	55.4	554	830	1107	1661	57.0	570	855	1140	1710
110*-14	2 x 5	56.2	562	844	1125	1687	57.9	579	868	1158	1737
126*-08	2 x 6	63.0	630	945	1260	1891	64.9	649	973	1298	1946
126*-10	2 x 6	67.4	674	1011	1348	2021	69.4	694	1040	1387	2081
129C-12	2 x 6	68.0	680	1020	1360	2040	70.0	700	1050	1400	2101
133C-14	2 x 6	68.8	688	1032	1376	2063	70.8	708	1062	1416	2124
142*-08	2 x 7	73.5	735	1102	1469	2204	75.6	756	1134	1512	2269
147*-10	2 x 7	78.3	783	1175	1566	2349	80.6	806	1209	1612	2418
152C-12	2 x 7	79.3	793	1189	1585	2378	81.6	816	1224	1632	2448

† - For R-404A applications multiply required capacity ratings by 0.98 and for R-134a selections multiply required capacity by 1.05 then make selection from R-22 table using corrected capacity.

Shaded areas indicate that specific models will require 1/2" diameter tubing over the standard 3/8" diameter tubing at certain operating TD's. At TD's not listed in the performance tables, conversion to 1/2" tube diameter tubing may be required for optimal performance. Contact factory for non-standard conditions.

* - Change asterisk in model number to a "B" for 3/8" tubes or a "C" for 1/2" tubes when specifying model number.



Electrical & Physical Data

Single Fan Width Models

WCE Model	Fan Data					Motor Data 3 Phase						Standard Ref.		Approximate		
	Qty.	Dia (in)	Nom CFM	dBA 30 ft [†]		Nom HP	Total Motor Amps		Min Circuit Amps		Watts (208V) ¹		Charge (lbs.)		Weight (lbs.)	
				FB2	Std		208-230	460	208-230	460	FB2	Std	R-404A	R-22 [*]	Net	Ship.
017	2	30	13,000	47.5	49.5	1/3	5.6	2.8	15	15	670	950	6.1	6.2	540	890
019			12,700										9.2	9.4	560	910
020			11,900										9.2	9.4	590	940
021			12,000										12.3	12.5	630	980
022			10,700										12.3	12.5	650	1000
028	3	30	19,100	49.5	50.5	1/3	8.4	4.2	15	15	1005	1425	13.6	13.9	790	1190
030			18,000										13.6	13.9	860	1260
032			16,500										18.2	18.5	940	1340
037	4	30	25,400	51.5	52	1/3	11.2	5.6	15	15	1340	1900	18.1	18.4	1030	1530
040			24,000										18.1	18.4	1090	1590
043			23,900										24.1	24.6	1170	1670
045			21,400										24.1	24.6	1210	1710
050	5	30	30,900	52	52.5	1/3	14.0	7.0	15	15	1675	2375	22.5 ²	22.9 ²	1360 ³	1910 ³
052			30,100										30.0 ²	30.6 ²	1400 ³	1950 ³
055			27,300										30.0 ²	30.6 ²	1500 ³	2050 ³
062	6	30	36,100	52.5	53	1/3	16.8	8.4	17.2	15	2010	2850	35.9 ²	36.6 ²	1580 ³	2230 ³
064			33,500										65.9	67.3	1795	2445
066			32,100										65.9	67.3	1855	2505
071	7	30	43,400	53	53.5	1/3	19.6	9.8	20.3	15	2345	3025	41.8 ²	42.6 ²	1840 ³	2610 ³
074			40,700										41.8 ²	42.6 ²	1910 ³	2680 ³
076			39,100										76.8	78.4	2080	2850

Double Fan Width Models

WCE Model	Fan Data					Motor Data 3 Phase						Standard Ref.		Approximate		
	Qty.	Dia (in)	Nom CFM	dBA 30 ft [†]		Nom HP	Total Motor Amps		Min Circuit Amps		Watts (208V) ¹		Charge (lbs.)		Weight (lbs.)	
				FB2	STD		208-230	460	208-230	460	FB2	STD	R-404A	R-22 [*]	Net	Ship.
034	4	30	26,000	51.5	52	1/3	11.2	5.6	15	15	1340	1900	12.1	12.4	1080	1780
038			25,400										18.2	18.6	1130	1830
041			23,800										18.2	18.6	1190	1890
044			24,000										24.3	24.8	1260	1960
046			21,400										24.3	24.8	1300	2030
051	6	30	41,000	52.5	53	1/3	16.8	8.4	17.5	15	2010	2850	18.0	18.4	1550	2350
056			38,200										27.1	27.6	1630	2430
060			36,000										27.1	27.6	1720	2520
065			33,000										36.1	36.8	1890	2690
075	8	30	50,800	53	53.5	1/3	22.4	11.2	23.1	15	2680	3800	35.9	36.7	2070	3070
080			48,000										35.9	36.7	2200	3200
086			47,800										47.9	48.9	2340	3340
088			42,800										47.9	48.9	2420	3420
100	10	30	61,800	53.5	54	1/3	28.0	14.0	28.7	15	3350	4750	44.8 ²	45.7 ²	2725 ³	3825 ³
105			60,200										59.7 ²	60.9 ²	2810 ³	3910 ³
110			54,600										59.7 ²	60.9 ²	3010 ³	4110 ³
126	12	30	72,200	54	55	1/3	33.6	16.8	34.3	17.2	4020	5700	71.5 ²	73.0 ²	3300 ³	4600 ³
129			67,000										131.5	134.2	3590	4890
133			64,200										131.5	134.2	3720	5020
142	14	30	86,800	54.5	55.5	1/3	39.2	19.6	39.9	20.0	4690	6650	83.4 ²	85.1 ²	3680 ³	5180 ³
147			81,400										83.4 ²	85.1 ²	3820 ³	5320 ³
152			78,200										153.2	156.4	4160	5660

† dBA corrections for other distances: 10ft = +10, 60ft = -6, 90ft = -9, 120ft = -12

* Multiply R-22 charge by 0.97 for R-134A, or 1.05 for R-502

¹ Multiply Watts by 1.1 for 230 or 460 Volts

² Multiply refrigerant weight by 1.84 for models requiring 1/2 inch tube coils

³ Multiply weight by 1.05 for models requiring 1/2 inch tube coils

Physical Dimensions

NOTES:

- * Mounting legs are retracted for shipping purposes, and must be lowered in position for unit installation.
- * All dimensions are in inches.
- * All mounting holes are 5/8" diam.
- * Units are available in horizontal airflow arrangements.

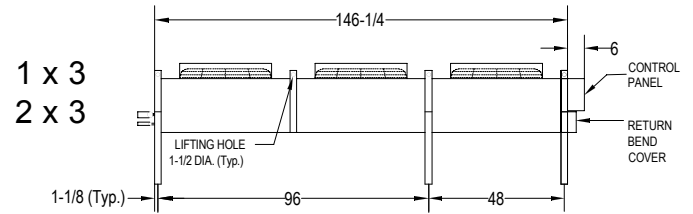
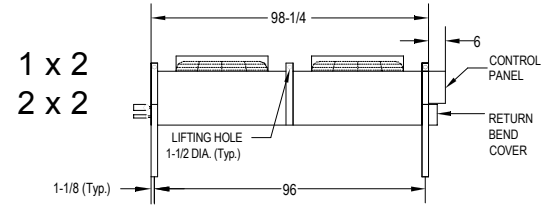

END VIEW - Double Fan Width Model

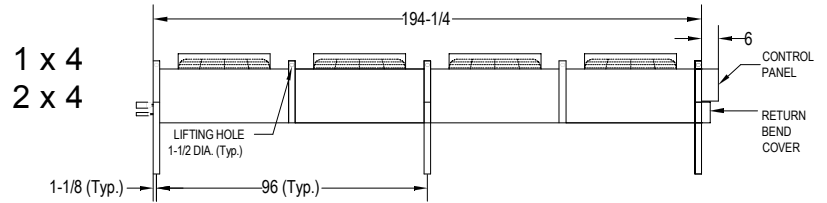
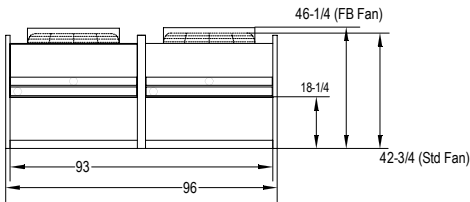

END VIEW - Single Fan Width Model

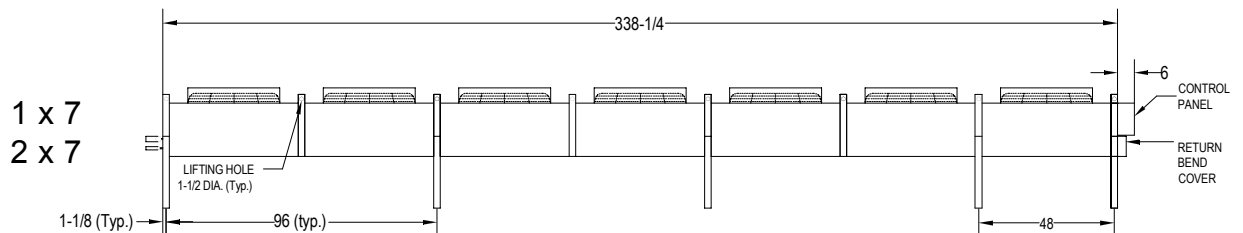
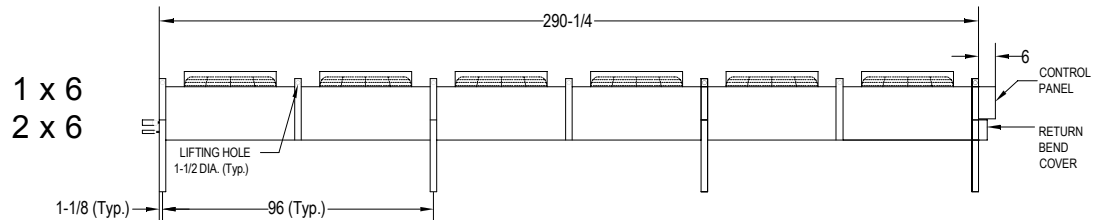
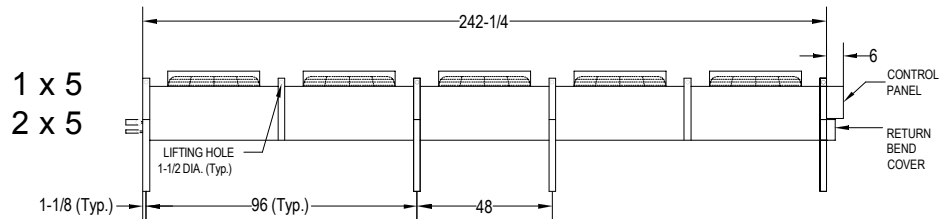
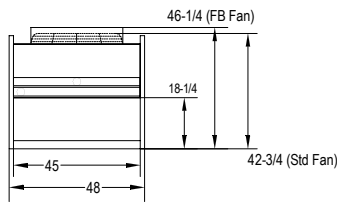

P/N - 122312050 04/04 RP 2000